

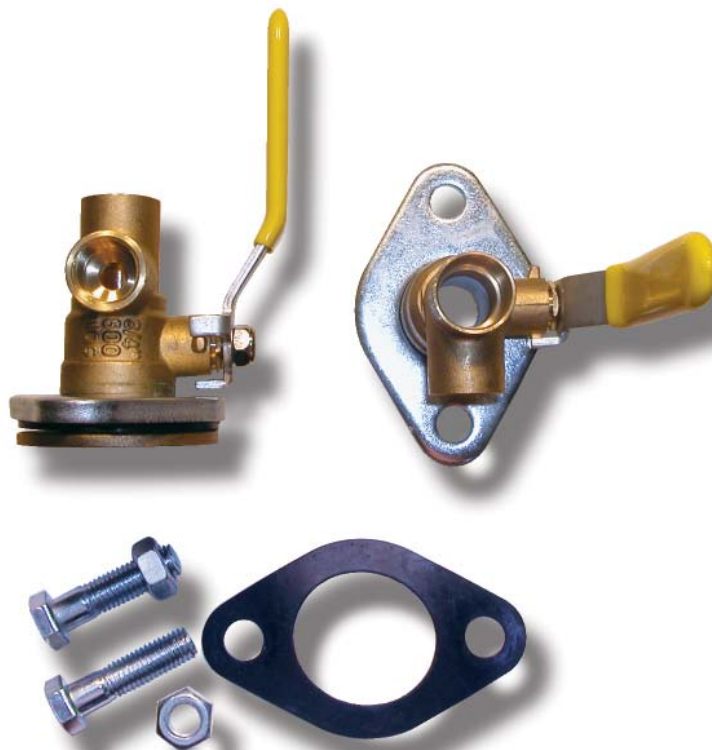

FPV2000



THE BOSTON VALVE Co.

A DIVISION OF BOSTON METAL PRODUCTS, LTD.
25 THURBER BLVD., UNIT #3
SMITHFIELD, RI 02917

TOLL FREE: 1-800-839-0013, TEL: 401-231-8537
FAX: 401-231-8491
WWW.BOSTONVALVE.COM

FPV2000 SERIES

FLANGED CIRCULATOR PURGE VALVE

A flanged by NPT, quarter turn purge valve with 1/2" NPT purge port. Used for circulator pump isolation.

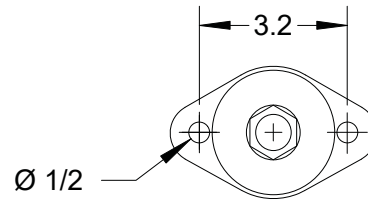
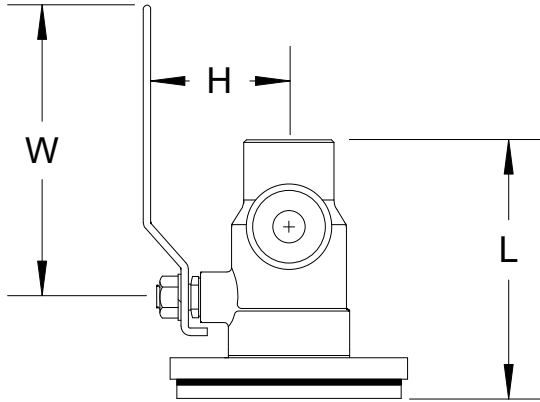

DIMENSIONS

CAT. NO.	SIZE	L	D	H	W
FPV0752000	3/4	3.16	.75	2.34	4.65
FPV1002000	1	3.41	1	2.52	4.65
FPV1252000	1 1/4	3.89	1.25	2.53	5.80

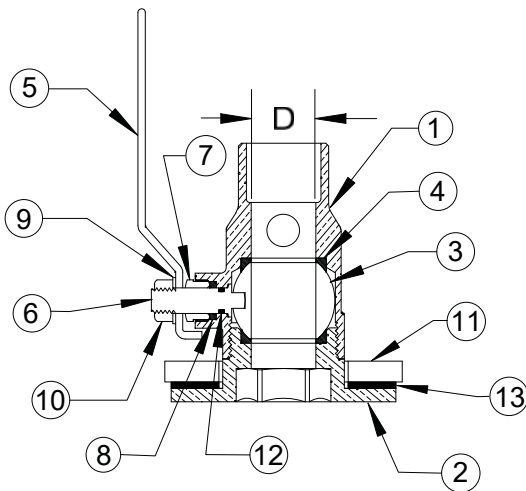

MATERIALS

NO	PART NAME	MATERIAL
13	WASHER	BUNA-N
12	O-RING	BUNA-N
11	FLANGE	STEEL, ZINC PLATED
10	NUT	STEEL, ZINC PLATED
9	LOCK WASHER	STEEL, ZINC PLATED
8	STEM PACKING	PTFE
7	GLAND NUT	BRASS
6	STEM	BRASS
5	HANDLE	STEEL, ZINC PLATED ,PLASTICOATED
4	SEAT	PTFE
3	BALL	BRASS, HARD CHROME PLTD.
2	END CAP	BRASS
1	BODY	BRASS